

Creo® Mechanism Dynamics Option

Analyze Dynamic Forces with a Powerful Prototyping Solution

Creo Mechanism Dynamics Option (MDO) allows you to simulate real-world forces virtually and analyze how your product will react to them. Gaining insight into product behavior early in the design phase allows you to build better products faster and more affordably.

Simulate real-world forces

With Creo MDO, you can determine, on a desktop, how your design will react to dynamic forces such as gravity and friction. Since you can do this analysis without having to build a physical prototype, you can perform your tests very early in the design phase when correcting problems costs much less. And, by building fewer physical prototypes, you not only cut costs, but you also reduce time-to-market because you're building a better quality product that is 'right the first time.'

Simulate based on real-world usage data

You can do even more when you combine Creo MDO with Creo Product Insight. Using Creo Product Insight, you can base your analyses on real-world usage data. Whether you obtain the usage data from sensors on your prototypes or through the IoT, Creo MDO allows you to perform countless analyses using the real world usage data as input, to understand if your design is over or under engineered.

Design and analyze concurrently

Creo MDO uses the same model data as Creo, so you won't waste time translating data for analysis. After implementing engineering changes, you simply rerun the analysis, generating a higher quality model, faster.

Key benefits

- Reduce development costs by creating virtual prototypes for desktop testing
- Work with real world usage data through Creo Product Insight
- Incorporate changes into the products faster and earlier, and get results right away from desktop testing
- Deliver higher quality products to market first by reducing development time
- Reduce warranty costs by generating a better estimate of your product's life
- Create more innovative products by using the time-savings gained from virtual testing to evaluate more design ideas

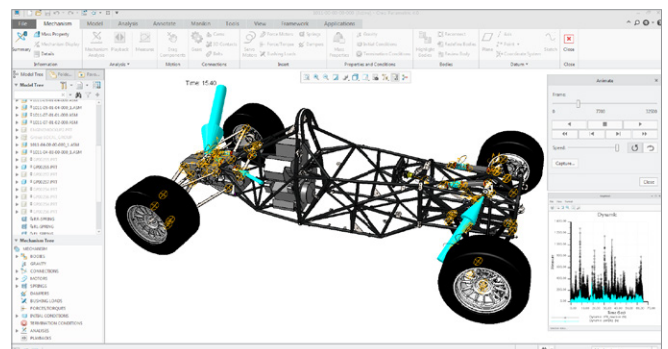

Creo MDO simulates real-world forces, reducing the number of physical prototypes and shortening the design cycle.

Capabilities and specifications

Explore real-world behavior

- Simulate gravity, springs, dampers, belts, gears, contact, and friction without creating a physical prototype
- Perform kinematic analysis (position, velocity, and acceleration analysis) as well as dynamic motion analysis (friction, gravity, and forces)
- Detect problems with clearances and interferences early in the design cycle
- Import behavioral data from applications such as Mathcad® or Microsoft® Excel®, and apply to existing models to determine their performance under this behavior

Easily share results via intuitive graphs

- Measure and graph custom specifications, such as velocity, at a specific joint
- Graph critical reactionary forces, (e.g., loads and torques) to better communicate how the product will respond in a specific environment
- Share results with others using graphs and animations; output your tabular data to spreadsheets for additional analysis
- Compare real-time motion with the graphical results

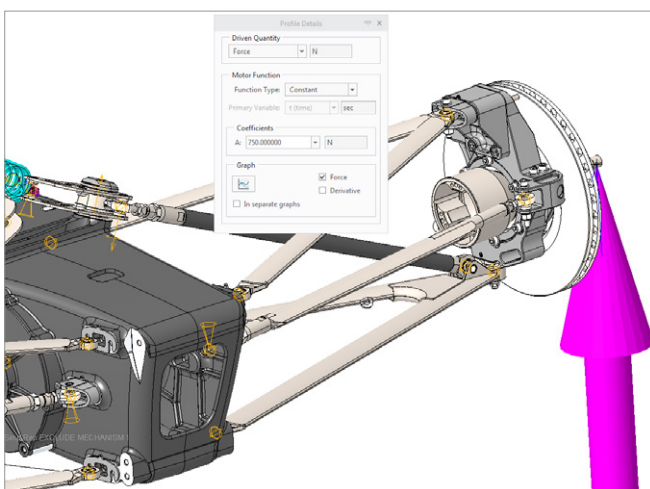

Dynamic forces are applied to the assembly using Creo MDO to optimize quality.

Increase flexibility to explore complex, real-world situations with advanced motion analysis

- Use static analysis to determine loading at a static point
- Analyze belt connections, slot motors, dynamic gears, and generic gears for all motion relationships
- Determine forces necessary to put a mechanism into motion, with inverse static loading (force balance)
- Easily create complex motion envelope parts of select components in your mechanism for use either in space claim studies or as place holders in any assembly
- Use Creo TOOLKIT™ to program a variety of complex behaviors, such as force-based gear systems, belts driven by flexible pulleys, linear beam and truss elements, and tire models
- Create user-defined forces and motor profiles as custom functions of measured force, torque, time, acceleration, velocity, or position
- Model intelligent, proportional-integral-derivative (PID) controllers, as well as non-linear springs and dampers

Integrate design and simulation

- Transfer reaction, gravity, and inertial loads directly to Creo Simulate™
- Set design feasibility and optimization study goals for kinematic and dynamic performance
- Leverage integration with other Creo solutions, such as Creo Simulate and Creo Behavioral Modeling Extension, both for optimization and complete virtual product analysis. Add product insight here.
- Leverage design information from other calculation applications, such as Mathcad, PTC's engineering calculation software, or Microsoft Excel
- Use parametric motion features to re-use and create variants of motion models

The Creo Advantage

Creo is a 3D CAD solution that helps you build better products faster by accelerating product innovation, reusing the very best of your designs and replacing assumptions with facts. Go from the earliest phases of product design to a smart, connected product with Creo. Add augmented reality to allow everyone to visualize your design. In the fast changing world of the Industrial IoT, no other company can get you to the substantial value as quickly and effectively as PTC.

Platform support and system requirements

For the most up-to-date platform support information, please visit the [PTC support page](#).

For more information, visit:

ptc.com/en/products/cad/creo/parametric

© 2018, PTC Inc. (PTC). All rights reserved. Information described herein is furnished for informational use only, is subject to change without notice, and should not be taken as a guarantee, commitment, or offer by PTC. PTC, the PTC logo, and all PTC product names and logos are trademarks or registered trademarks of PTC and/or its subsidiaries in the United States and other countries. All other product or company names are property of their respective owners. The timing of any product release, including any features or functionality, is subject to change at PTC's discretion.

J10697-Creo Mechanism Dynamics Option-EN-0112