

PTC® Creo® Complete Machining Extension

The Power to Drive Virtually Any Type of NC Machine

With PTC Creo Complete Machining Extension (CMX), manufacturing engineers and machinists now have a powerful, comprehensive package of NC programming capabilities and tool libraries for production machining. Bottom line: You can easily create an unlimited variety of programs for CNC machines.

Achieving concurrent engineering

With PTC Creo CMX Complete Machining, manufacturing engineers can work concurrently with designers to automatically incorporate design changes. With integrated collaboration between two fundamental areas of development, you have the power to increase product quality, reduce scrap, and decrease production time and costs.

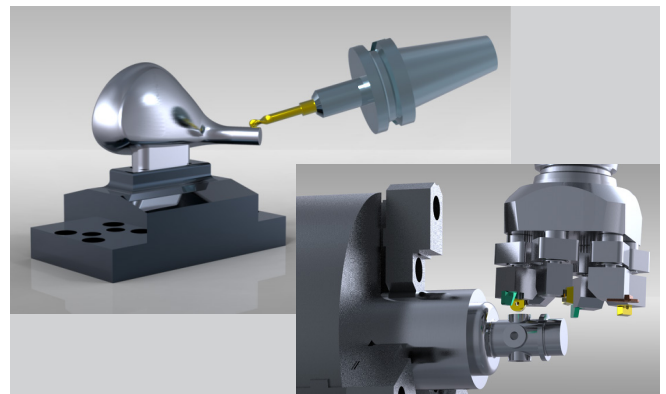

PTC Creo CMX gives you the broadest range of capabilities to meet all your production machining needs.

Key benefits

- Supports 2.5 to 5-axis milling, 2 and 4-axis turning, 2 and 4-axis wire EDM, and multi-axis mill/turns
- Includes the 2.5-axis, feature-based machining capability of PTC Creo Prismatic and Multi-Surface Milling Extension
- Extends the full associativity of PTC Creo Parametric™ capabilities into manufacturing
- Eliminates the inaccuracies and inconvenience of exporting PTC Creo Parametric geometry to third-party machining software

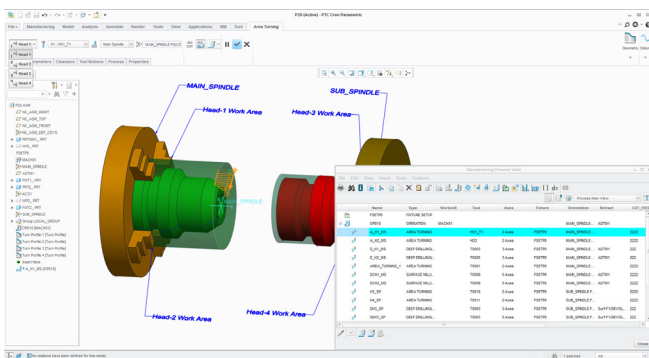

Create NC toolpaths faster using graphical dynamic toolpath display, which allows you to visualize the resulting toolpath even when is under definition, and leverage a powerful process manager with easy-to-use dashboard controls.

- Features a best-of-breed production machining programming system for families of parts having many variations of the same basic design
- Reduces or eliminates physical part program prove-outs by simulating the process of material removal on NC machines
- Enables efficient development and refinement of the most demanding geometry and free-form surfaces
- Includes GPOST for creating and updating post-processors for any type of CNC machine
- Improves manufacturing set-up and quality control processes with in-process probing support
- Provides robust data management of manufacturing models and deliverables with PTC Windchill® PDMLink® and PTC Windchill MPMLink® (optionally available)

Capabilities and specifications

- Graphic toolpath generation for production machining applications
- Data import that supports IGES, STEP, VDA, and DXF
- Works with PTC Creo CAD data and imported data from other CAD systems
- Tooling library with feed, speed, and cutting conditions based on material
- Tool gauge checking with all tool shapes: end mill, ball mill, bull nose, and tapered
- Ramping, plunging, or helical tool entry and exit
- Automatic shop floor documentation: tool setup, part setup, and process documentation
- Drag-and-drop reordering of toolpaths
- Supports family tables for manufacturing models
- Family parts machining: Program once and propagate to all instances

- Toolpath editing and manipulation
- Support for subroutines
- Cutter radius and tool length compensation
- Multiple fixture offset control
- Holder degouging for roughing and finishing toolpaths
- Dynamic toolpath preview to visualize the NC step while under creation or edition

2-Axis milling

- Feature-based milling: face, slab, pocket, through pocket, step, profile, channel, slot, through slot, boss top, flange, o-ring, rib top, chamfer, round, undercut, entry hole, hole pattern
- Free-hand machining
- 4-axis and 5-axis indexing and tool positioning
- Tombstone machining
- Capture machining processes and strategy
- Thread milling
- Automated hole-making

3-Axis milling

- A modernized Volume Milling sequence with a new UI and streamlined workflow
- Roughing: Z-level, plunge milling
- Reroughing: by previous tool, corner picking, flat surfaces
- Finishing: Z-level, parallel planes, isolines, cut lines, and projected
- Rest milling, single or multi-pass thread milling pencil tracing, and engraving
- Automatic corner machining
- Rest finishing sequence for improved cornering

Wire EDM

- 2-axis contouring with advanced conics
- Non-planar 4-axis YXUV and XYQR with manual and auto-synchronization
- No core cut pocketing
- Support for multiple rough and skim cuts
- Support for glue stop and technology changes in cut

Turning

- ID, OD, and face area turning
- ID, OD, and face grooving
- Automatic update of in-process workpiece
- Dual turret 4-axis synchronization
- Standard and custom threading
- Support for solid tools, multi-tasking, and tool flashing
- Live tooling, mill/turn “C” and “Y” axis support

Integrated NC simulation

- Solid toolpath simulation
- Multi-window display
- Automatic error detection
- Machine kinematics simulation and collision detection

Multi-axis milling

- A modernized 3,4, and 5 axis trajectory milling
- Multi-surface, 5-axis machining: conventional, isolines and cutlines
- 5-axis helical cutline machining for high-speed cutting

- 5-axis swarf milling
- 5-axis hole-making
- Support for lead and tilt angles
- Advanced tool axis control with a new functionality to define the axis on-the-fly using 3D draggers
- Tool axis containment with pivot curve and pivot axis

High-speed machining

- Specialized roughing and reroughing strategies
- Slope-based finishing
- Helical spline approaches and exits
- High-speed friendly connections
- Smooth, arc-like transitions for facing and finishing sequences

Multi-task machining

- Expanded capabilities to support up to 4 heads and 2 Spindles (main and sub-spindle)
- Multi-task machining synchronization with the capability to synchronize at-start or synchronize at-a-point on the toolpath
- Gantt chart and play-path available while defining a synchronization

NC post-processing

- Graphic NC post-processor generator
- Interactive, online, context-sensitive help
- Extensive library of machine tools and CNC controls
- Direct NURBS output

Language support

- English, German, French, Italian, Spanish, Japanese, Chinese (Simplified and Traditional), and Korean

Platform support and system requirements

- Microsoft® Windows® 7 and XP

Please visit the [PTC support page](#) for the most up-to-date platform support and system requirements.

© 2014, PTC Inc. All rights reserved. Information described herein is furnished for informational use only, is subject to change without notice, and should not be taken as a guarantee, commitment, condition or offer by PTC. PTC, the PTC logo, Product & Service Advantage, Creo, Elements/Direct, Windchill, Mathcad, ArborText, PTC Integrity, Servigistics, ThingWorx, ProductCloud and all other PTC product names and logos are trademarks or registered trademarks of PTC and/or its subsidiaries in the United States and other countries. All other product or company names are property of their respective owners.

J3408-PTC Creo CMX-EN-0214